

# vft black line pumps



## Black Hawk BH1-4H

# vft Black Hawk 1

## Up to 6,9 bar and 260 l/min.

The **BH1-4H** is a portable, light, robust and versatile fire pump. It is designed for rapid intervention in wildland fires. Equipped with a **VFT\_1SP4** 1-stage centrifugal pump and a 2.5 HP \* **Honda GXH50** 4-stroke engine, it offers an excellent performance of 6.9 bar maximum pressure and a maximum flow of 260 l / min, with which any emergency self-protection and firefighting situation can be faced.

- > Components made of high quality aluminum and stainless steel.
- > With the best quality / price ratio.
- > Spare parts available through [customer.service@valfirest.com](mailto:customer.service@valfirest.com).
- > 2 years warranty.

### Applications

- Direct attack with hose laying.
- Self-protection maneuvers with sprinklers.
- Tandem pumping over long distances.
- Assembly in skid units and extinguishing vehicles.

### Features

- Extremely light and resistant and compact.
- Made of lightweight aluminium alloy.
- Integrated fuel tank.
- Detachable and foam compatible pump.
- Flat black polyethylene base with anti-vibration elements.
- Built-in clutch for easy starting that allows to stop the discharge of water without stopping the engine.
- Ergonomic carry handle mounted on the top for a comfortable transport.
- Available with or without hand primer built into the base.
- Optional transport backpack.



### Certified standards



**2006/42/CE**

UNE EN-14466:2006+A1 2009

UNE-EN 1028-2:2003+A1 2008

Engine with EPA, CARB and EU stage V emissions certificate.

### Specifications

Engine	Honda GXH50
Centrifugal pump	vft 1-stage
Fuel tank	0,77 l.
Dry weight	9,5 kg.
Maximum pressure	6,9 bar
Maximum flow	260 l/min.

## 1. Honda GXH50 engine

Gasoline powered 4-stroke combustion engine with integrated fuel tank.

SPECIFICATIONS	GXH50
Engine	4-stroke gasoline
Bore x Stroke	41.8 X 36 mm
Cylinder capacity	49,4 cm <sup>3</sup>
Compression ratio	8 : 1
Power	2,1 HP a 7000 rpm
Max Torque	2,7 Nm a 4500 rpm
Start	Manual
Tank capacity	0,7 l.
Oil capacity	0,25 l.
Dimensions (l. x w. x h.)	225 x 274 x 353 mm.
Dry weight	5,5 kg.
Certifications	EPA, CARB, EU stage V



\* Net engine power is 2.1 HP at 7000 rpm. Mass production of engines can make vary this value.

## 2. 1-stage centrifugal pump VFT\_1SP4

Compact, efficient and reliable 1-stage pump, made of anti-corrosive and hardened aluminum. Stainless steel axis adapted for transmission clutch that allows stopping the pump without stopping the engine. High quality mechanical seal and aluminum turbine. Foam concentrate compatible pump.



### Technical specifications VFT\_1SP4

Suction	1.5" NPSH
Impulsion	1.5" NPSH

## 3. BH1-4H Performance

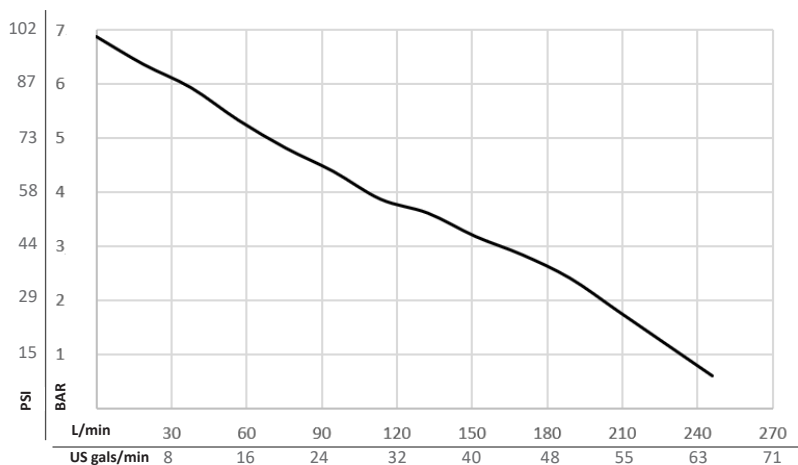

### Performance data BH1-4H

Maximum flow	260 l/m
Maximum pressure	6.9 bar
Max. meters of water	70.4 mH2O

Pressure	Flow		
	[Bar]	[PSI]	[US gals/min]
5.3	76.8	58.6	15.5
3.9	56.5	113.6	30
2.4	34.8	189.3	50

## 4. Dimensions

Length: 35 cm. | Width: 28 cm. | Height: 42 cm.

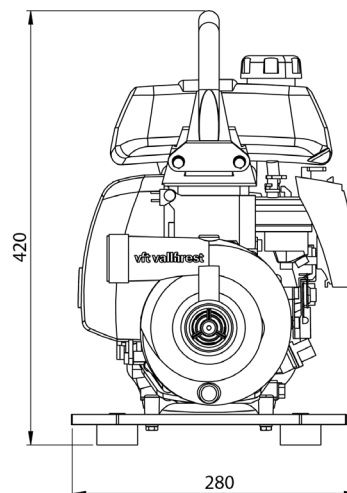
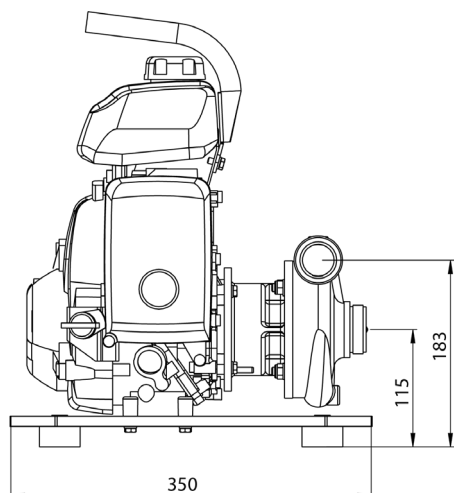

## 5. Available configurations

### Portable fire pump BH1-4H

#### DVD3004-14TOA

- Does not include manual priming system. It can be used a primer with a coupling to connect it to the pump discharge. See the list of optional accessories below.



### Portable fire pump BH1-4H (with manual primer)

#### DVD3004-14T1A

- Includes an installed manual priming system with supports to anchor it to the base.



## 6. Required components for operation

### WATER SUCTION

A suction hose and foot valve are required to filter the water.

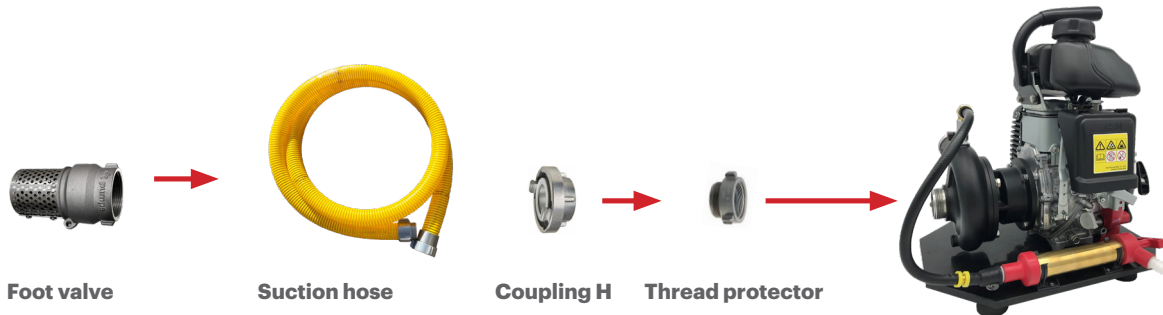

### OPERATION

A coupling wrench is required to tighten and loosen thread protectors / adapters. It is necessary to manually prime the pump before operating.

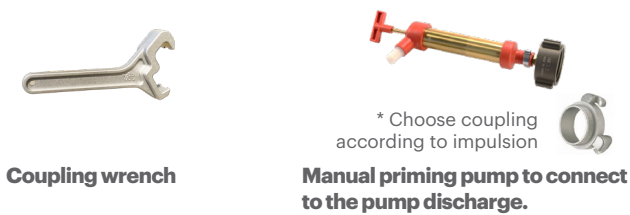

### FUEL FEEDING

By a portable bottle. See the different types of bottles available according to regulations.



### WATER IMPULSION

For the impulsion, choose the couplings according to the type of hose and the laying configuration: direct attack or connection in series or in parallel of several fire pump units.

\* See our **Pump setup** sheet for more information.

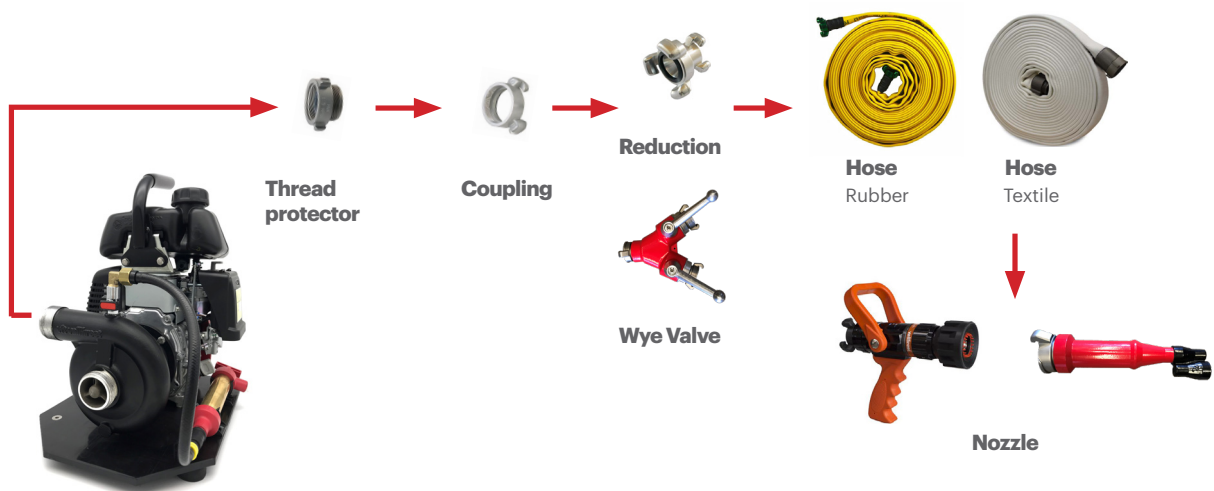

## 7. List of components

### Thread protectors

Necessary to protect the original threads of the pump and adapt the NPSH thread to any other type of thread, allowing the connection of other couplings.

**DVD3107-00001 NPSH-NPSH 1-1/2"**

**DVD3107-00002 NPSH-BSP 1-1/2"**

**DVD3107-00003 NPSH-NH 1-1/2"**



### vft Pumps coupling wrench

Allows safe tightening and loosening of thread protectors and couplings.

**DVD3112-00001**



### vft Foot valve

The foot valve with non-return system filters the water and allows the suction circuit and the pump to be primed.

**DVD3105-00001 NPSH 1-1/2"**

**DVD3105-00002 BSP 1-1/2"**

**DVD3105-00003 NH 1-1/2"**



### Suction hose

Flexible wire reinforced suction hose.

**DVD3101-00001 1-1/2" NPSH // L=3m**

**DVD3101-00002 1-1/2" BSP // L=3m**

**DVD3101-00003 1-1/2" NH // L=3m**

**DVD3101-00004 1-1/2" Storz 52-C // L=3m**



## 8. Optional accessories

### Manual priming pump

Allows to manually prime the circuit through the pump impulsion.

- DVD3104-00001** NPSH 1-1/2"
- DVD3104-00002** BSP 1-1/2"
- DVD3104-00003** NH 1-1/2"
- DVD3104-00004** Storz 52-C
- DVD3104-00005** BCN 45



### Manual priming pump kit 1/4" BSPT

To mount on the 1/4 "threaded connection of the pump. Includes valve and support clips for the primer that can be screwed onto the base of the fire pump.

- DVD3103-00001**



### Load-hauling backpacks

Resistant and light aluminum structure, with padded harness for transporting the fire pump, fuel tanks, hoses and accessories.

- BVB0403-AAA0A** vft Hose carrying backpack
- BVB0404-AAA0A** vft Hose Carrying Backpack without transport bag



### Hose choke

Tool that allows to quickly cut off the water flow to carry out operations such as, for example, lance changes or adding and removing hoses during direct attack.

- DED5800-00000** Hose choke FC-2540
- DED5801-00000** Textile hose choke



### Protection base

Folding base made of resistant and waterproof canvas. It serves as protection for the fire pump in aggressive terrain and to contain tools and accessories during operation.

- DVD3114-00001** Protection base



\*See the price list to know all the components available depending on the threads, coupling ties, diameters, etc. In case of doubt, contact your commercial agent or directly with [customer.service@vallfirest.com](mailto:customer.service@vallfirest.com).

Do you have any doubt? Contact us: [customer.service@vallfirest.com](mailto:customer.service@vallfirest.com) | T. +34 938 678 779